

Gas Discharge Tube Lightning Arrestor with N-type connectors



Features:

- ✦ Frequency: DC to 6GHz
- ✦ Ultra Compact Design
- ✦ Excellent RF Performance
- ✦ Multiple Strike Capability
- ✦ 20 kA (8x20µs) Surge Capability
- ✦ Rugged and Waterproof
- ✦ Bi-directional Protection

RF Specifications

Frequency	VSWR	Insertion Loss (dB)
dc – 6GHz	1.15 typ 1.25 max	.10 typ .15 max

- ✦ Nominal Impedance – 50Ω
- ✦ Through Current: 10A Max
- ✦ RF Power: 30W (45dBm) max

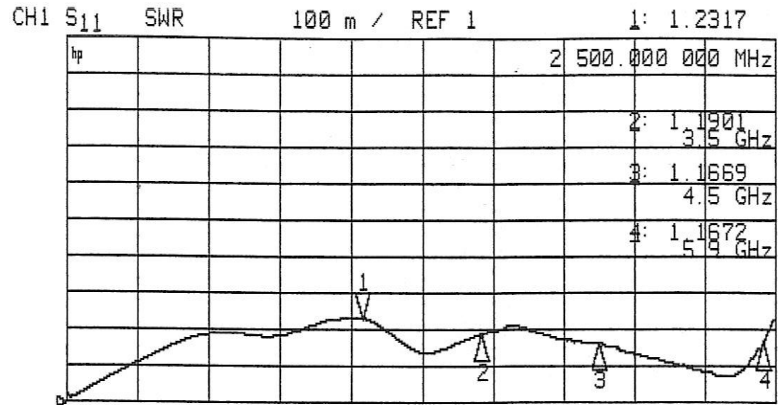

Transient Specifications

- ✦ Gas Discharge Tube 90V rated
- ✦ Maximum Transient: 20kA (8x20µs)
- ✦ Multiple Strike: 5kA 10 times
- ✦ Let-through: 644Vpk/ 500 µJ
(Input 4kV 1.2x50µs / 2kA 8x20µs)

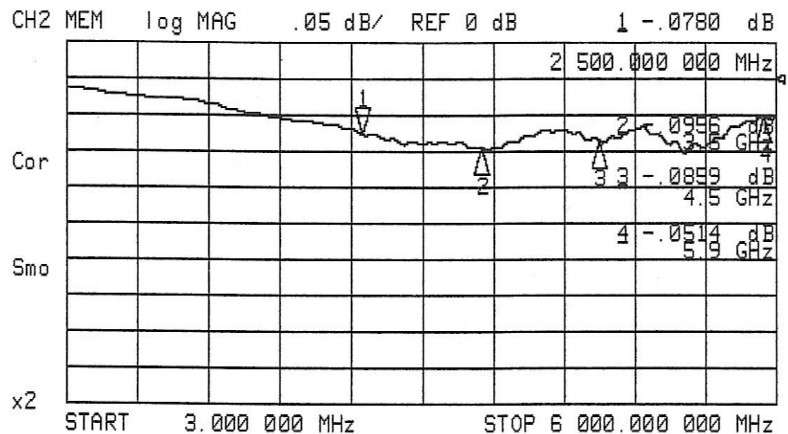

Mechanical Specifications

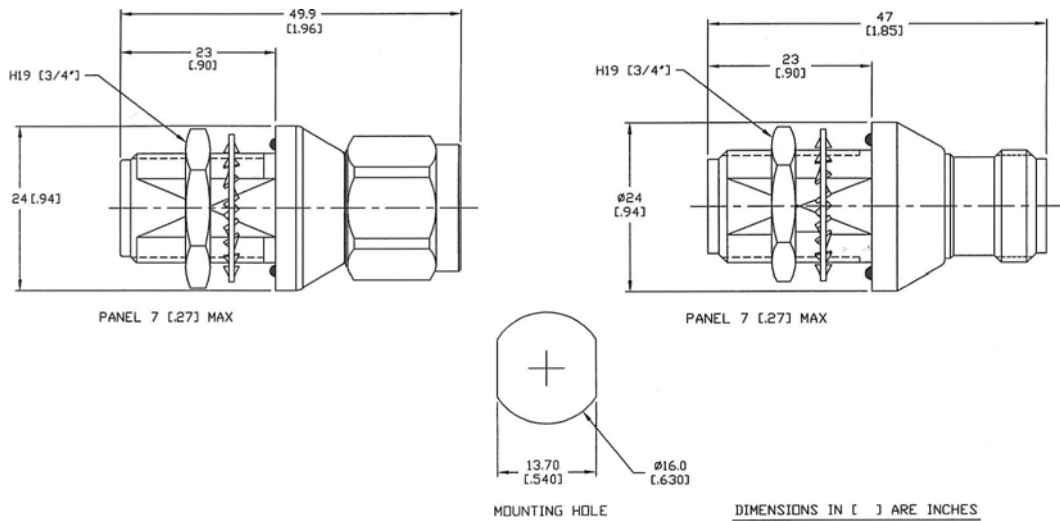

Weight: 2 ounces (50g) typical

Environmental Specifications

Temperature Range	-40°C to +90°C
Salt Fog	MIL-STD-202 Method 101D / Condition B (35°C/96 hrs)
Immersion	MIL-STD-202 Method 104A / Condition A (65°C to 25°C w/NaCl – 2 cycles)
Moisture Resistance	MIL-STD-202 Method 106E (65 °C/98% RH condensing/240 hrs)
Temperature Shock	MIL-STD-202 Method 107D / Condition B-1 (25 cycles -65°C to +125°C)
Life (Elevated Temperature)	MIL-STD-202 Method 108A / Condition A (96 hours at 100°C)
Dust and Waterproof Rating	IEC529 IP68 (dust-tight and water proof 24 hrs / 1 m)
Vibration	MIL-STD-202 Method 204D / Condition D (10Hz-2kHz 0.06"DA/20g)
Mechanical Shock	MIL-STD-202 Method 213 / Condition A (50g/11ms ~24")

Material and Finish

Component	Material	Finish
Outer Parts	Brass	Nickel
Center Contact	BeCu	Gold
Insulator	PTFE	
Gasket	Si Rubber	

Part Number: PTC ONx ONF 09 E

Connector types, replace with ONF ONF for female to female PTC or with ONM ONF for male to female PTC